

CD Motor operating mechanisms



HV Switching

The versatility of the CD mechanism allows multiple options for operation, and adaptation to specific requirements.

We know how

Our range of motor operating mechanisms is designed to ensure the best performances and reliability, which are the result of our 60-year old experience.

Over 50,000 disconnectors and switchers installed in more than 100 countries worldwide are the guarantee of best-buys.



Operation and safety

The electrical operation of the disconnector through the CD mechanism can be done remotely, or from local push buttons. A local/remote selector prevents any interference between the two control modes. The applicable voltage range extends from 85% to 110% of the rated voltage.

The manual operation of the disconnector is possible by the means of a manual handle. The insertion of the handle is allowed only if the electrical interlocks are permissive and the pushbutton is energized and operated. This action also switches off automatically the motor supply, to prevent any accidental electrical operation.

This handle allows also the padlocking of the mechanism, preventing any operation (see picture).

Depending on the model (see table) the actuation of the integrated earthing switch can be done manually by a lever or a handle, or electrically as well.

A mechanical interlock ensures that the motions of the shafts are possible only in safe condition.



Reliability and maintenance

- The design is mechanically non-reversible, to prevent any unwanted motion of the disconnector, under the effect of wind, electrodynamic or other external efforts.
- The housing is made of aluminium alloy, to prevent any corrosion, and guarantees a high protection degree (IP 44, or higher upon request).
- An anti-condensation heater prevents harmful moisture condensation inside the cabinet.
- The external components are either aluminium alloy or hot dip galvanized or stainless steel.

To ensure the best dependability on site, the CD has undergone the most severe test conditions:

- extra low temperatures down to - 50° C
- heavy wetting
- extended mechanical endurance (exceeding IEC standard requirements)

Due to its lifetime greased gearbox, no maintenance is required on the CD mechanism.

Design and construction

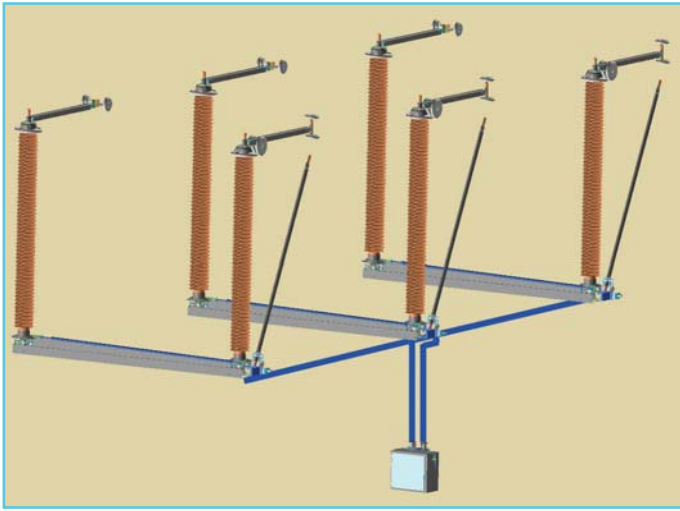

Fig. 1

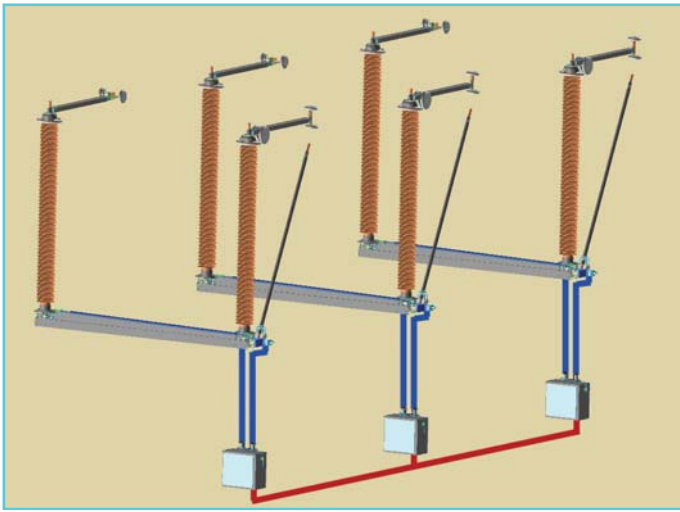

Fig. 2

Depending on the model (see table), the CD mechanism includes 1 or 2 motors (3-phase AC or DC) and single or twin 2-stage gearboxes providing a high torque, exceeding that required by the disconnecter. This ensures a high safety factor to guarantee proper operation, whatever the site conditions are.

It can operate the three poles of a disconnecter through driving shafts and rods (Fig 1) or with one drive per pole: one master and two slave units (Fig 2).

The power operated switches position signalling is given through auxiliary switches, actuated by adjustable cams, and which can be of the normally open (NO), normally closed (NC), early make (EM) or late break (LB) type. These switches allow also electrical interlocking with other devices of the substation.

The motor limit switches are also adjustable in the same way.

These adjustment possibilities ensure that, in any conditions, the position signalling reflects exactly the position of the main contacts.

To improve the easiness of adjustment operation, this series of CD features a door-lock in open position and a coupling with the vertical tube.

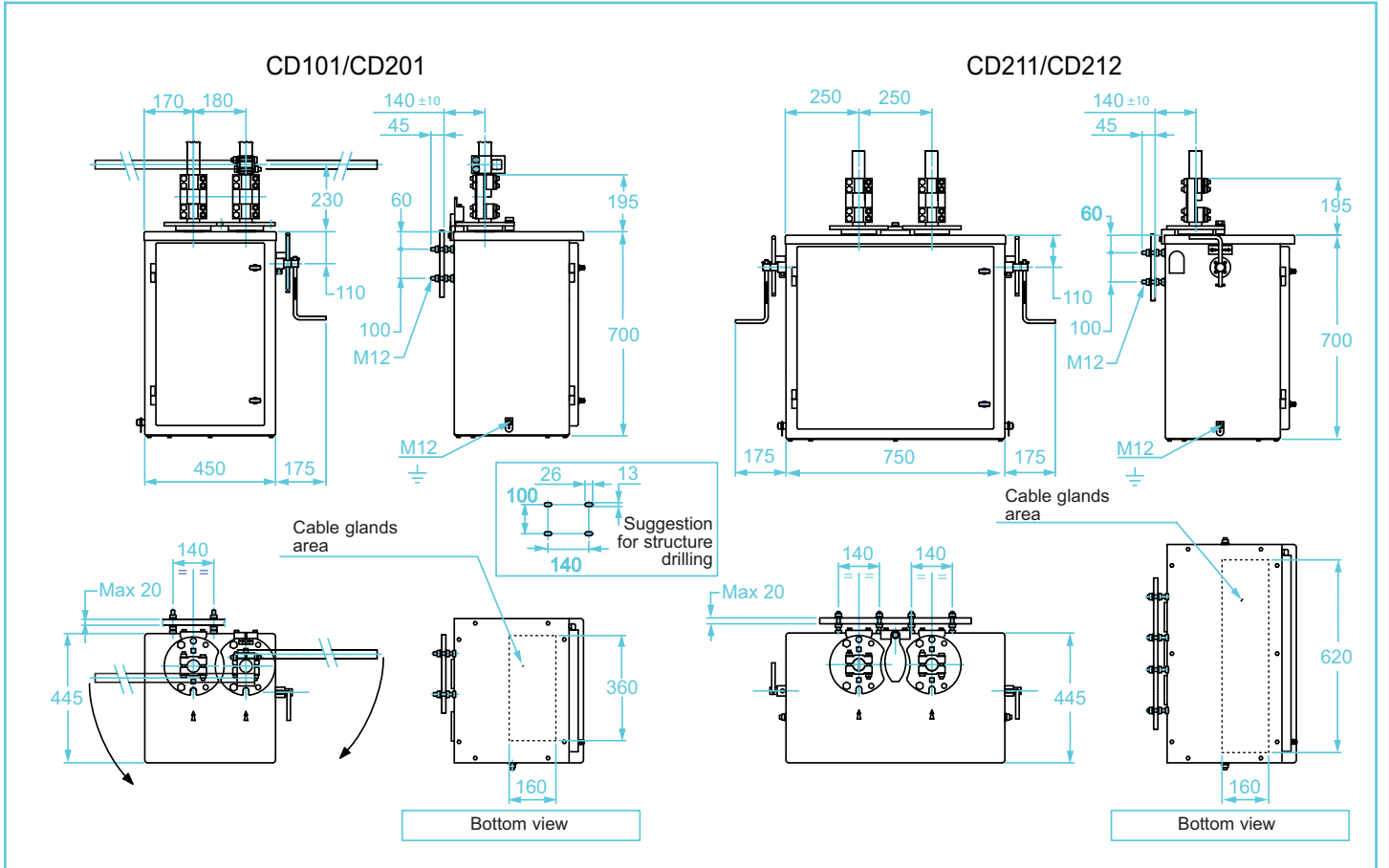

Technical data

	CD101	CD201	CD211	CD212
Rated torque	800 Nm			
Disconnecting switch	Motor	Motor	Motor	Motor
Earthing switch	NA	Manual (by lever)	Manual (by handle)	Motor
Weight	50 kg	60 kg	95 kg	100 kg
Operating angle	90-180°			
Operating time (motor)	<20s			
Motor				
- rated power	≤600W			
- rated voltages (+10%-15%)	110 - 220 V _{dc} 230/240 V _{ac} 3 ~			
- frequency	50-60 Hz			
Anticondensation heater				
- rated power	30 W			
- rated voltage	110 - 240 V			
Auxiliary switches				
- rated current	10 A			
- breaking capacity (as per IEC 62271-1)	10 A (250 V _{ac}) 2 A (220 V _{dc})			
- standard quantity	DS	6 NO + 6 NC		
	ES	4 NO + 4 NC		

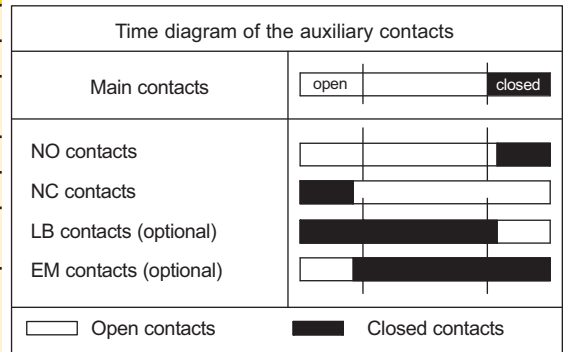

Electrical diagram legend

M	Motor
IAM	Magnetohermic circuit breaker
CA	Opening contactor
CC	Closing contactor
Fa	Opening limit switch
Fc	Closing limit switch
PA	Opening pushbutton
PC	Closing pushbutton
MLD	Local / remote selector switch
BM	Interlocking motor manual
RA	Anti-condensation resistance
ESS	Electromagnetic interlocking device
PSS	Release pushbutton of ESS
A-B	Auxiliary switches (disconnecter)
C-D	Auxiliary switches (earthing switch – if applicable)

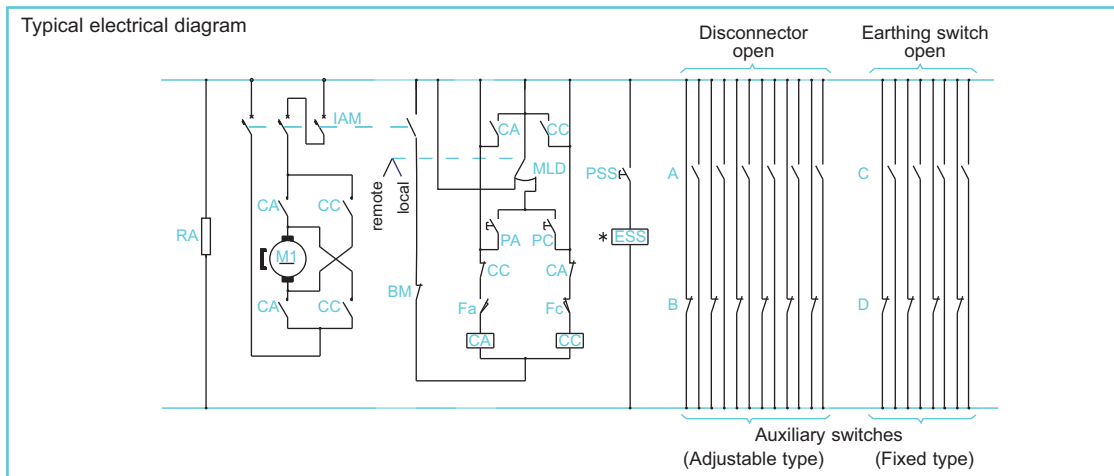

* Manual operation of the main blades is possible only when ESS is energized.

Optional features

Upon request, the mechanism can be equipped with various accessories:

- electrical interlock of the earthing switch
- signalling lamps
- heater with thermostatic control
- protection of heaters by mini CB
- additional auxiliary switches
- provision for key interlocks
- key-lock of the housing door
- ...



COELME

Via G. Galilei, 1/2 - 30036 Santa Maria di Sala (VE) - Italia
Tel.: +39 041 486022 - Fax: +39 041 486909
E-Mail: contact@coelme-egic.com, www.coelme-egic.com

EGIC

60b, rue L. et R. Desgrand - 69625 Villeurbanne CEDEX - France
Tel.: +33 4 72 66 20 70 - Fax: +33 4 72 39 08 65
E-Mail: contact@coelme-egic.com, www.coelme-egic.com